



BUHLER
Topwhite



Do not open without
safety goggles



TopWhite™ II
Whitener
BSPB.

TopWhite™.

Quality. Performance. Economy.

The Bühler TopWhite™ whitener BSPB is used for whitening (i.e. removal of bran) of brown rice to white rice. It uses the vertical abrasive top to bottom working principle, which has been proven to achieve the highest whole grain yield. Its main fields of application are the rice milling industries. The whitener can also be applied to grain, wheat, barley, and peas processing industries.



- Flexible Adaptation
- Uniform and gentle whitening
- Intensive cooling
- High capacity and efficiency
- Minimum space requirement
- High product quality
- High level of sanitation
- Low power consumption
- Easy Maintenance



Rice



Barley



Peas



Pulses



Easy access

- Wide open doors give full access to the milling chamber
- Easy machine inspection
- Shortest maintenance time
- Highest machine availability
- User-friendly design and high quality material

Easy adjustment

- Central adjustment of brakes
- Equal setting of all three brakes
- Easy adaptation to different requirements
- Adjustment even during whitening

Easy maintenance

- Quickly exchangeable screen frames with sieves
- Long lasting silicium carbide rings
- Minimum wear and tear of parts

Good sanitation

- Connection to an efficient aspiration system
- Reliable bran discharge
- Clean milling chamber and working room
- Intensive cooling

Highly flexible and adaptable rice production.

The TopWhite™ whitener BSPB adapts easily to all varieties of rice for whitening. The various options make the machine most suitable for all sorts of rice and ensure the production of perfect white rice of all kinds.

High efficiency thanks to gentle whitening process.

Through a smooth flow of rice and the efficient aspiration system inside the machine, the rice is whitened very gently. This minimizes breakage of the rice during the whitening process and ensures maximum profit.

Guaranteed uniformity and quality of the end product.

The option of various adjustments even when the machine is in operation – like counter weights or the adjustable gap between screens and stones – enables uniformity and guarantees high quality of the end product.

TopWhite™.

Designed to fulfil the highest needs in gentle whitening.

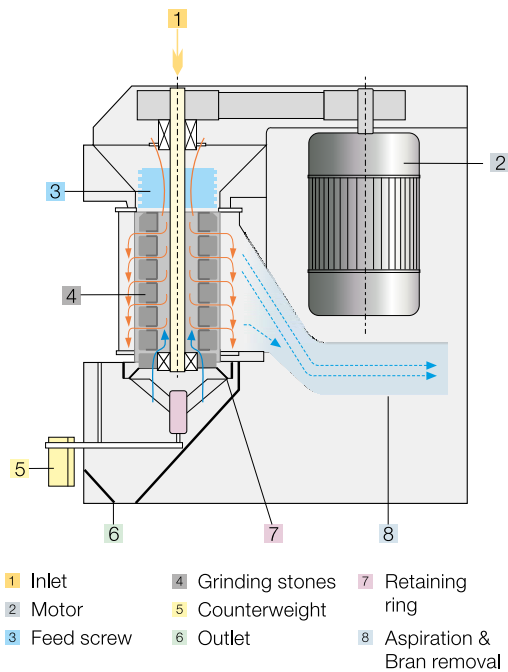

Working principle

The TopWhite™ uses the vertical abrasive, top to bottom working principle which has been proven to achieve the highest whole grain yield. The grain enters the whitener via two inlets and is guided into the processing chamber by a feed screw. There, it is exposed to careful whitening of the grain surface between the six abrasive rings and the screen. As the rotor is dynamically balanced a smooth running is assured. The whitening intensity is controlled by two easily adjustable means the counterweight of the retaining gate and the gap between rotor and brakes. For coarse adjustment, the vertical brakes attached to the sieve basket are moved simultaneously by simply turning a handwheel and thereby tuning the resistance inside the chamber. The fine setting is done by changing the counterweight position of the retaining gate, thus controlling the pressure. The gravity flow of the product allows a trouble-free restart in case of an emergency shut-down.

Aspiration system

The TopWhite™ is equipped with an optimised aspiration system that fulfills two tasks very efficiently: it cools the rice and thereby reduces breakage and supports the conveying of the bran out of the whitening chamber into the exhaust system. Therefore, aspiration air is guided partly through the product and partly around the screens. The aspiration hood, being easy to open or remove, gives full access to the heart of the machine. For best sanitation, no moving parts are involved in the bran removal system.

The ammeter and the vacuum gauge allow the monitoring of the motor current and the negative pressure of the applied exhaust system.

TopWhite™.

Technical Specifications.

BSPB

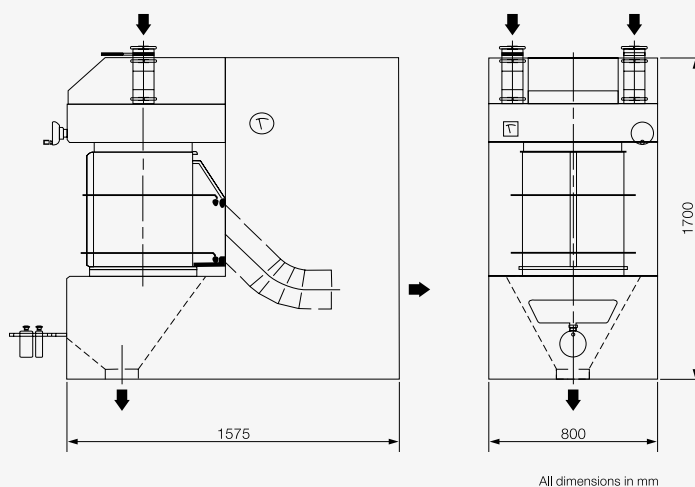

Dimensions, air and power requirements

BSPB

Capacity** (kg/h)	3500 – 8000*
Motor (kW)	45
Aspiration m ³ /min	37 – 55
Approx. weight kg - Unpacked	35
Approx. weight kg - Rail worthy packing	1300
Approx. weight kg - Sea worthy packing	1500
Approx. weight kg - Sea worthy packing	1600
Volume m ³ seaworthy packing	4.3

*Depending on the type of product and finished product quality
**Capacity as brown rice input

Buhler (India) Pvt. Ltd.

13-D KIADB Industrial Area
Attibele 562 107
Bengaluru

T +91 (0)80 6777 0000

F +91 (0)80 6777 0183

buhler.bangalore@buhlergroup.com
www.buhlergroup.com

SO 31657 en 0518 Z&B 182042