



Vibrosifter.
MKZH.

High sifting capacity and sanitation. **Food safety that pays.**



Vibrosifter, for efficient sifting of the end product.

Application.

The vibrosifter is used for centrifugation of coarse and fine bran or for the sifting of hard-to-sift, floury, or granulated products.

Flexible applications.

The vibrosifter is available in two sizes, with a throughput range up to 2.6 tons/hour. The standard option is available in painted steel, whereas a stainless steel option is also available for the parts that come into contact with the product.

Operating principle.

In addition to conventional sifters, the vibrosifter has a vibrating sifting body which has a positive impact on the sifting effect or cleanliness of the screen. The vibration is generated by eccentric fastening of the sifting box to the sifting mantle on the rotor axis.

Advantages at a glance:

- High sifting capacity
- Fast screen changes
- Superior sanitation
- Superior accessibility

Flexible applications. Efficient sifting.

Technical data of the MKZH vibrosifter at a glance:

Model	Through-put t/h	Aspiration m ³ /min	Sifting mantle Diameter Ø mm	Sifting mantle Length mm	Net screen area m ²	Motor power (4-pole) kW	Weight (approx.) net kg
MKZH-4510F	0.7	3	450	1000	1.00	4	460
MKZH-4510B	1.5	3	450	1000	1.00	5.5	460
MKZH-6012F	1,0	6	600	1200	1.66	5.5	720
MKZH-6012B	2.8	6	600	1200	1.66	11	720

F=floor/filter flour (nylon 202 µm) B=brans/4th grist passage (wire 0.32 mm)

Model	Dimensions mm				
	A	B	C	D	E
MKZH-4510	1535	1387	1380	655	864
MKZH-6012	1835	1647	1690	805	1070

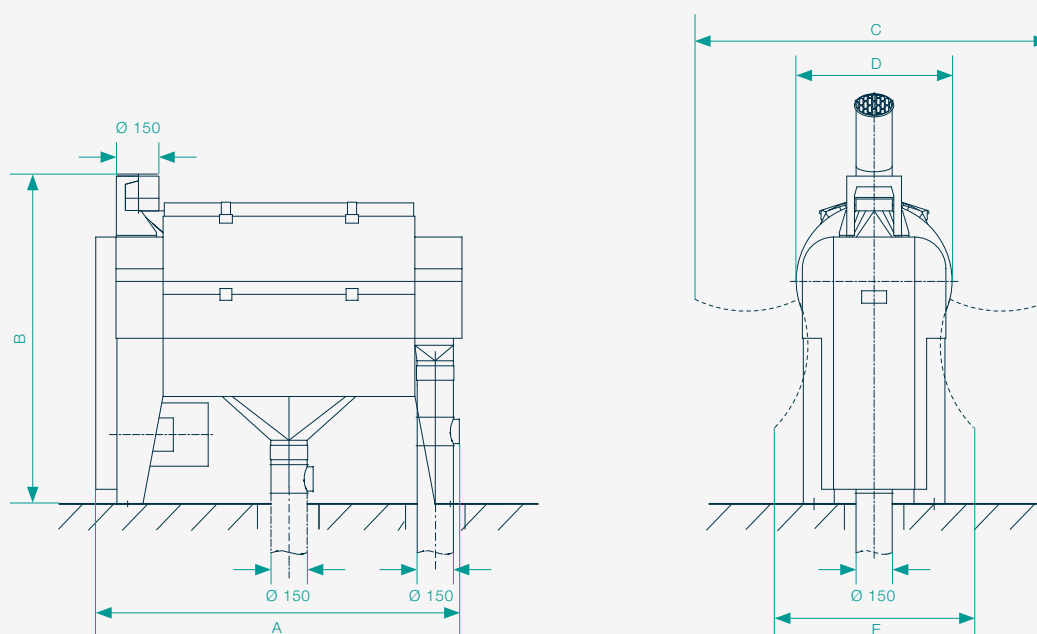

Bühler AG

CH-9240 Uzwil
Switzerland

T + 41 71 955 11 11
F + 41 71 955 66 11

buhlergroup.com/milling

Flyer Vibrosifter MKZH en 03/18 ZACC