



Combi-stoner.  
**MTCG.**

## Two functions, one solution. **For maximum process efficiency.**



**Combistoner MTCG**  
Combined functions for maximum efficiency

### **Broad range of applications.**

The Combistoner is a universal application for efficiently separating stones, glass and other solid parts from various types of grain such as wheat, durum, maize, rye, oats, barley and rice. This ensures that the raw product is prepared cleanly and creates the foundation for producing high-quality products.

### **High throughput capacity.**

By mastering two separation steps in one machine, the Combistoner provides the optimal combination of high performance on a small footprint. In the first step, the product flow is classified into high-density and mixed fractions. Then, the mixed fraction goes directly onto the next process step while the high-density fraction is reprocessed in the destoner. There, heavier contaminants such as stones, metal and glass are efficiently and reliably removed from the raw product. The pre-classification makes it possible to have higher throughputs of 28t/hr in a small space.

# Efficient destoning and classifying. For top product quality.

## Combined functions.

The Combistoner unifies two otherwise separate functions - destoning and classifying - through an integrated combination solution. The carefully thought-out design and Bühler's process knowledge ensure that it can be easily and quickly integrated into the plant with stable operation.

## High performance in a small space.

The sturdy construction as well as the high-quality materials used assure reliable and steady operation. Investment in grain cleaning is thus significantly optimized by blending two functions into one machine with the resulting high performance.

## Advantages

- Broad range of applications
- High throughput capacity
- Destoning with high selectivity
- Classification into mixed and high-density product
- Energy savings of up to 30%

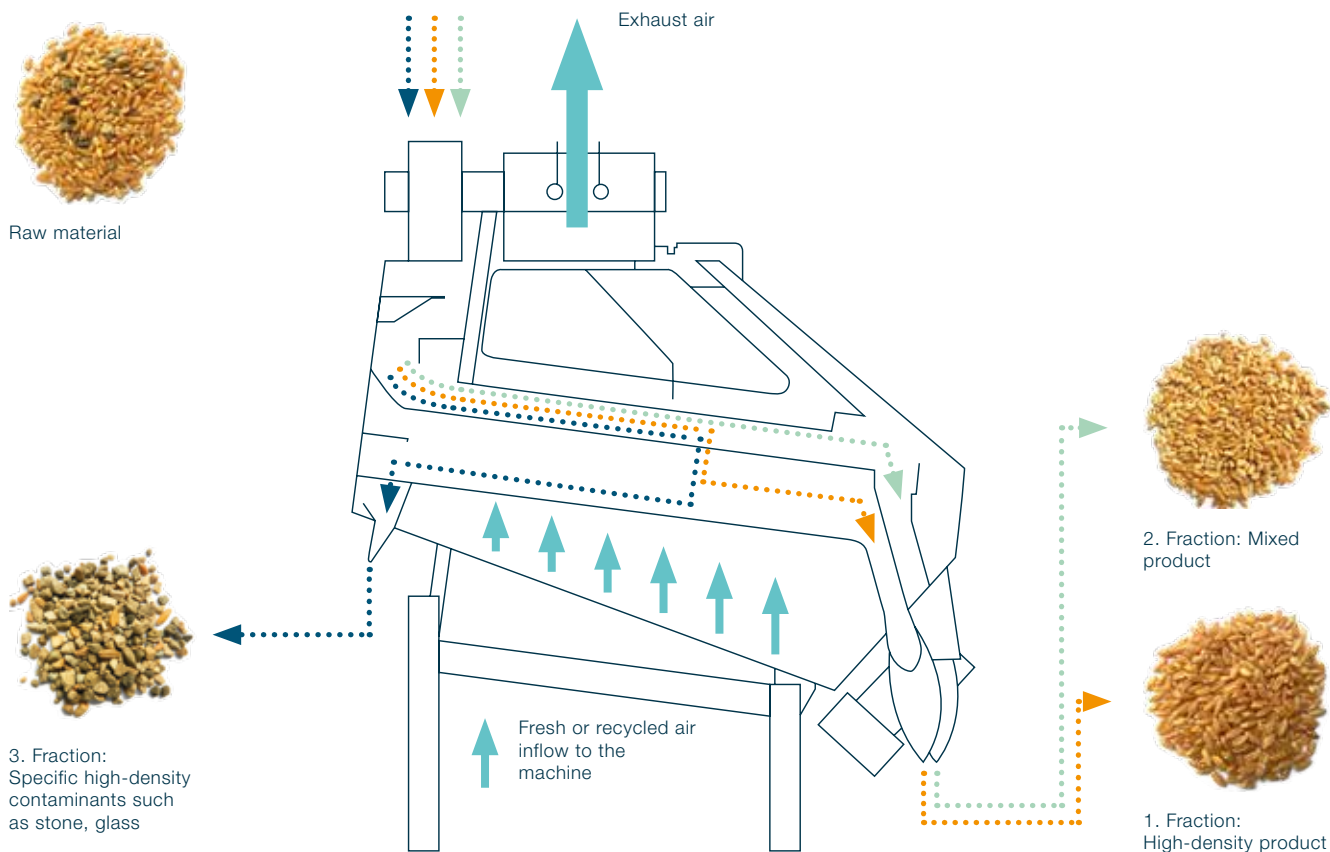

Working principle of Combistoner MTCG

# Broad range of applications. **Universal use for a large capacity range.**

## Large product variety.

The Combistoner MTCG is suitable for a great variety of grain types, such as wheat, barley, maize, rye, oats and rice. They are reliably and efficiently cleaned of high-density particles on the Combistoner.

## Broad capacity range.

The Combistoner's integrated design means that it can cover a very broad capacity range, reaching from a minimum of 10t/hr up to a maximum of 28t/hr (for wheat).



Wheat



Durum



Maize/corn



Barley



Oats



Paddy rice



Rye

# Recycled air instead of fresh air. **For energy efficient, economical operation.**

The standard Combistoner works with fresh air. Optionally, the Combistoner can be supplemented with an air recycling separator. This returns a large part of the filtered process air back into the process in a closed circuit.

## **Energy savings up to 30%.**

Compared to fresh air systems, energy consumption with the air recycling separator MANW drops up to 30%. Plus, the amount of space needed and the investment costs for the plant are significantly reduced. Because of the smaller exhaust air volume, the central filtering system as well as the aspiration system can be designed smaller and thus significantly more cost-effective.

## **Reliable operation with low maintenance costs.**

By utilizing an air recycling separator, the process air is reliably cleaned of small particles. This reduces the maintenance costs and downtime of the plant to a minimum.

Combined with the optionally available air recycling separator, the result is a particularly high-capacity and energy efficient integrated system for destoning and classifying.



Combistoner MTCG-150/150 AR with air recycling separator MANW-60

# Custom maintenance service. For maximum protection of investment.



**Original Bühler spare and wear parts**  
Quickly available worldwide and in top quality

## Easy installation and integration.

The Combistoner is a key component in the cleaning process and has a direct influence on the end product quality. To maintain the desired throughput capacity and availability at a constantly high level, regular maintenance is indispensable. Critical spare and wear parts should always be available on site for the machinery operation.

Bühler Customer Service supports customers through comprehensive consulting, customized maintenance plans and supply of wear parts. It also offers services to keep production processes permanently in motion, minimize expensive downtime and protect investments.

The recommendations are based on decades of experience by the Bühler experts in grain mills worldwide. Our global service network means that spare parts and service technicians are on site promptly.

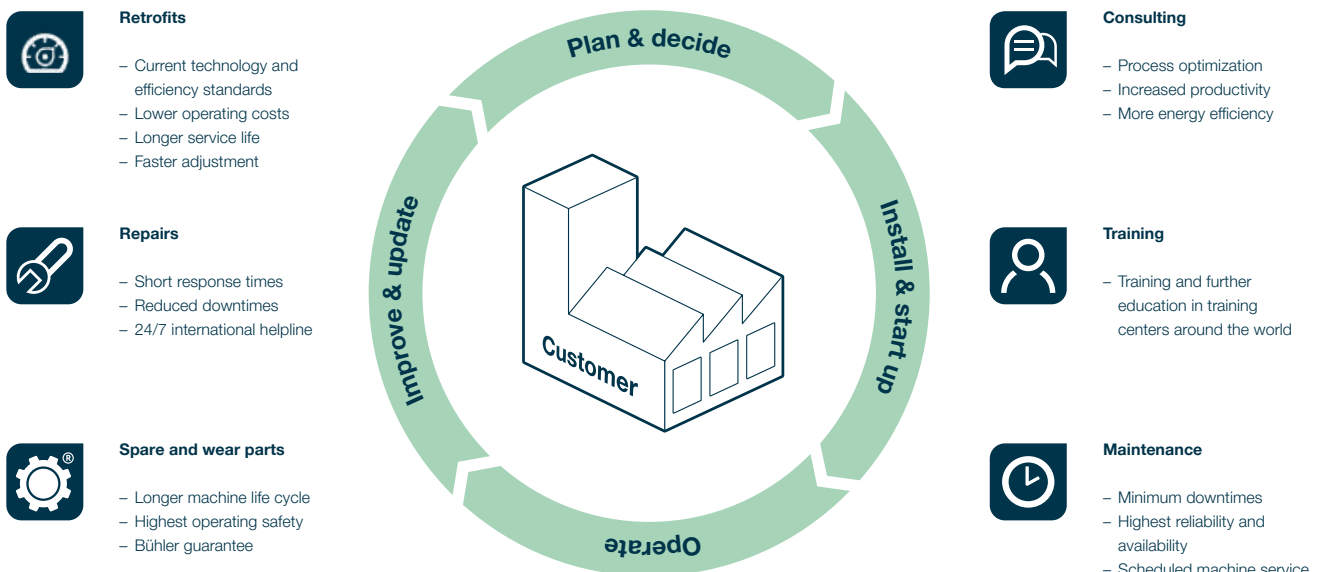

# Custom maintenance service. For maximum protection of investment.

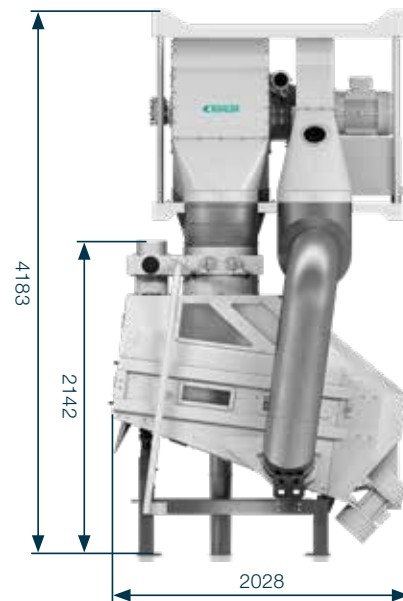
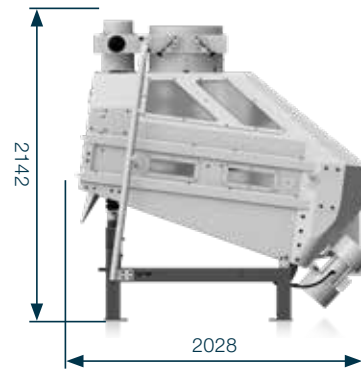

	Performance (at 50 Hz)				Weight kg	Capacity Wheat t/h
	M1 kW	M2 kW	M3 kW	M4 kW		
<b>MTCG-150/150</b>	2x0.75				1180	10 - 28
<b>MTCG-150/150 AR (with MANW-60)*</b>	2x0.75	15	0.06	0.55	1680	10 - 28

\* Minimal building clearance = 4500 mm

- M1 Main drive MTCG
- M2 Drive radial ventilator
- M3 Drive sieved drum
- M4 Drive rotary valve

## **Bühler AG**

Gupfenstrasse  
CH-9240 Uzwil, Switzerland

T +41 71 955 11 11

F +41 71 955 66 11

[milling@buhlergroup.com](mailto:milling@buhlergroup.com)  
[buhlergroup.com/milling](http://buhlergroup.com/milling)

Flyer Combistoner MTCG en 03/17 ZACC

